

104

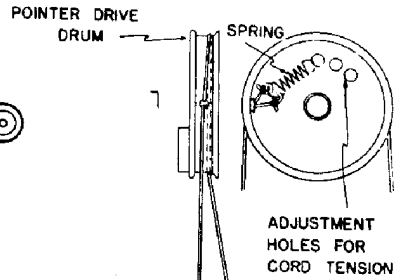

105

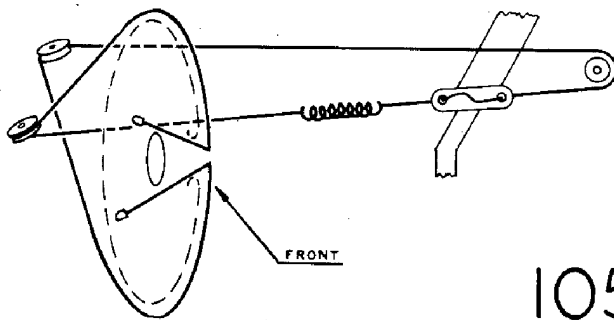

106

CORD DRIVE FOR BAND INDICATOR DRUM

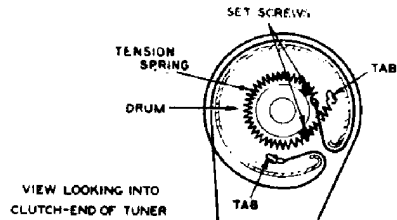
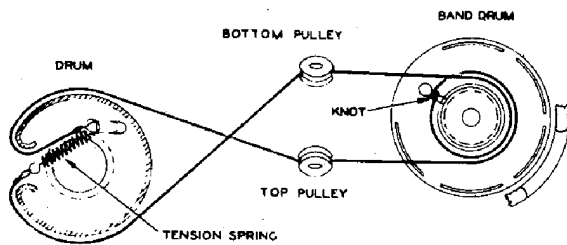

VIEW LOOKING INTO CLUTCH-END OF TUNER

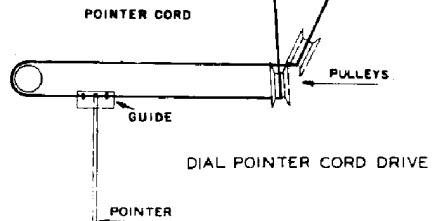

DIAL POINTER CORD DRIVE

107

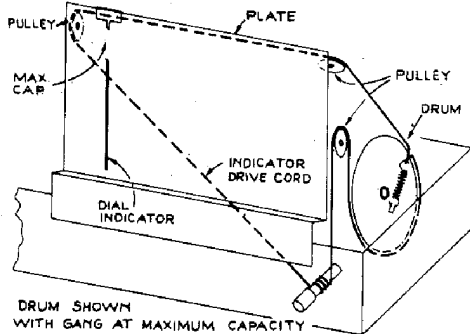

DRUM SHOWN WITH GANG AT MAXIMUM CAPACITY

108

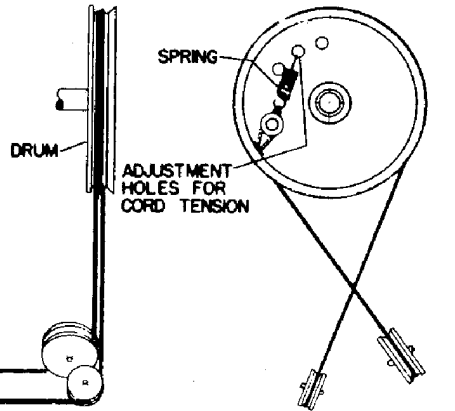
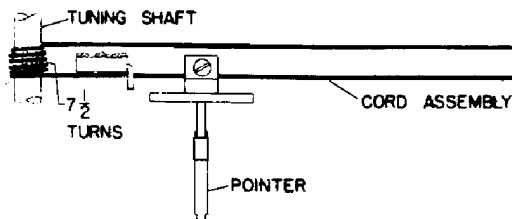

POSITION OF DRUM ASSEMBLY WITH COIL CORES FULLY IN.

TUNING KNOB & SHAFT ASSEMBLY

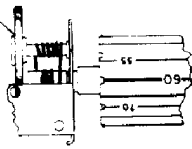

TO RECALIBRATE AFTER REPLACING DRIVE STRING, TURN COIL CORES FULLY IN, THEN HOLD DIAL SHAFT STATIONARY WITH PLIERS, AND REVOLVE DIAL WITH FINGERS UNTIL THE 60 CALIBRATION LINE IS IN RELATION SHOWN TO BRACKET

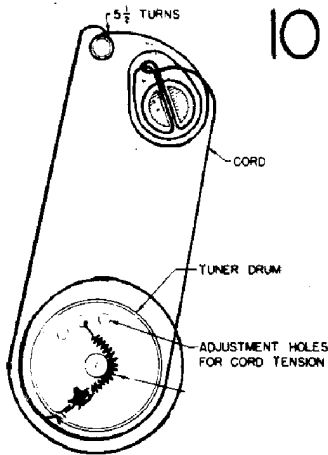
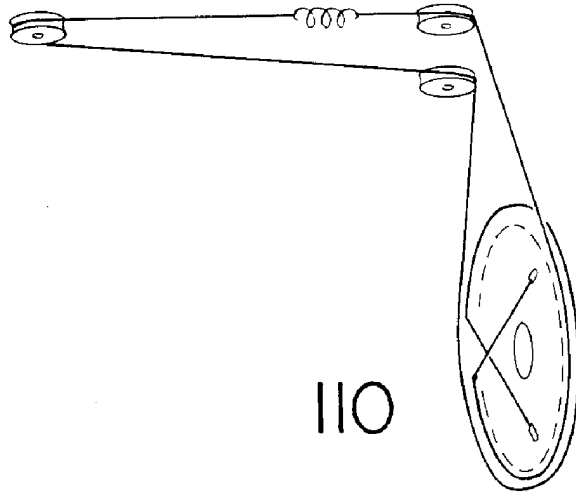

109

110

TONE INDICATOR DRUM

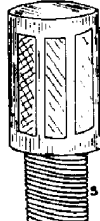

SPRING

SPRING

2 1/2 TURNS

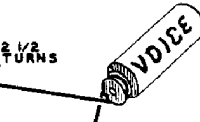
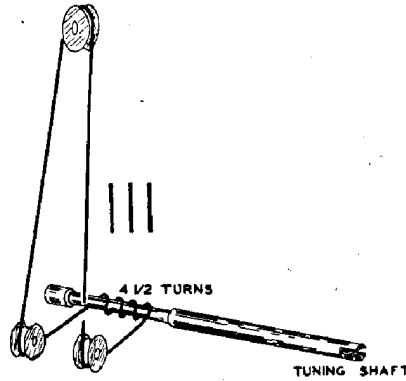

SPRING

TONE VOLUME

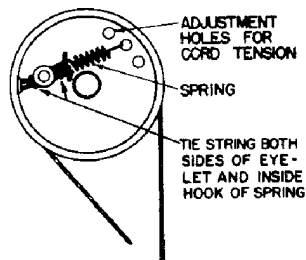

ADJUSTMENT HOLES FOR CORD TENSION

SPRING

TIE STRING BOTH SIDES OF EYE-LET AND INSIDE HOOK OF SPRING

POSITION OF DRUM ASSEMBLY WITH COIL CORES FULLY IN.

POINTER DRIVE DRUM

112

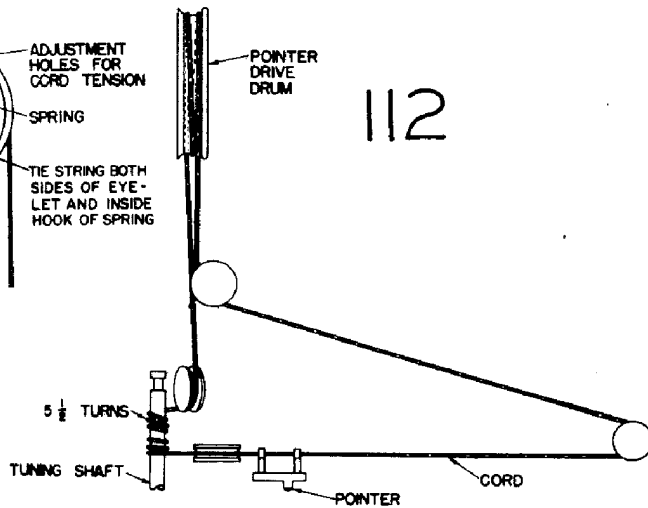

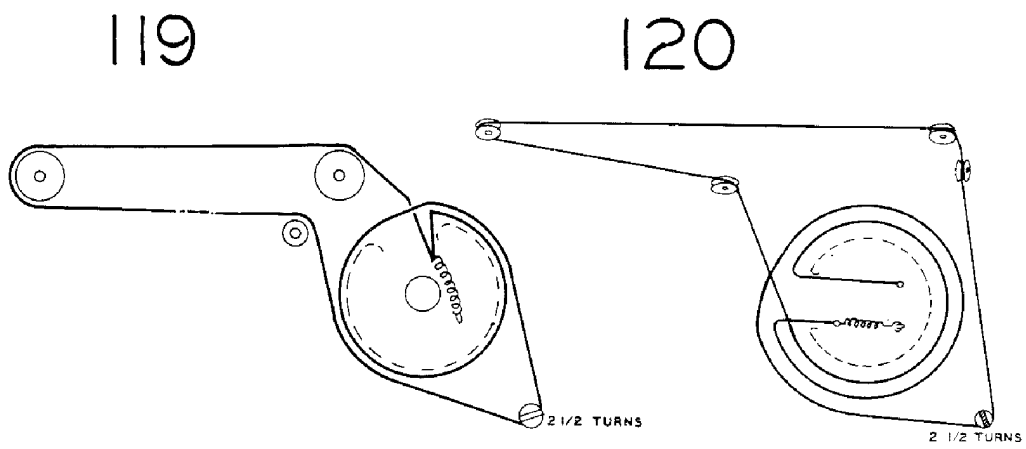
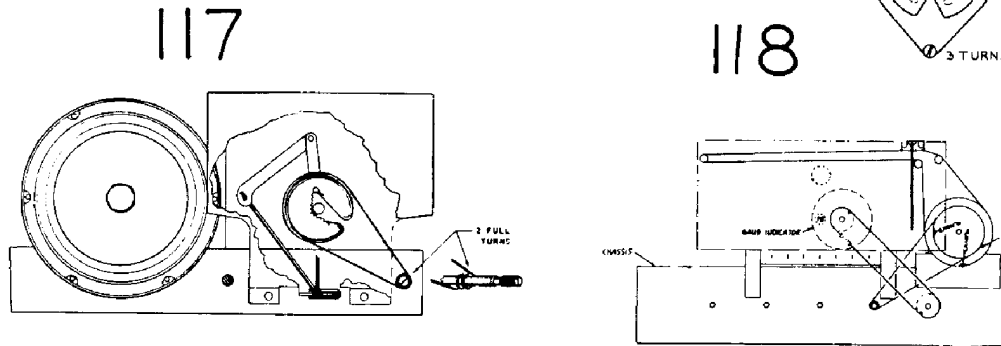
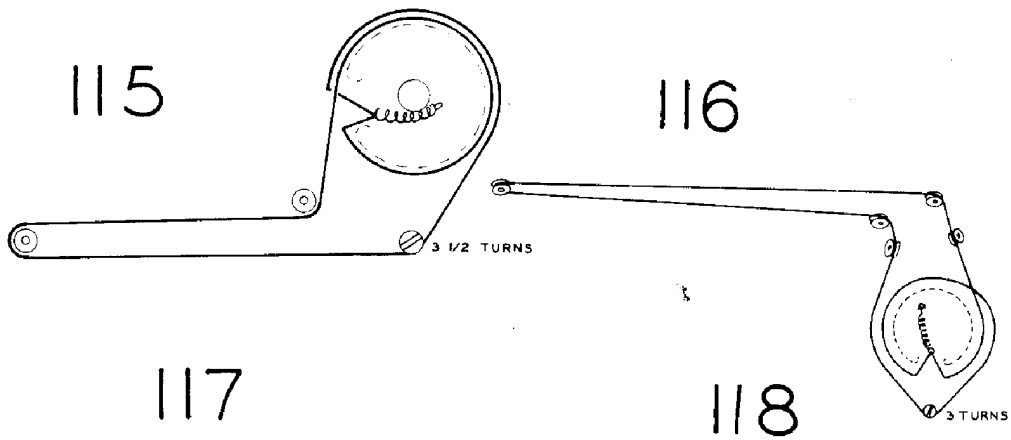
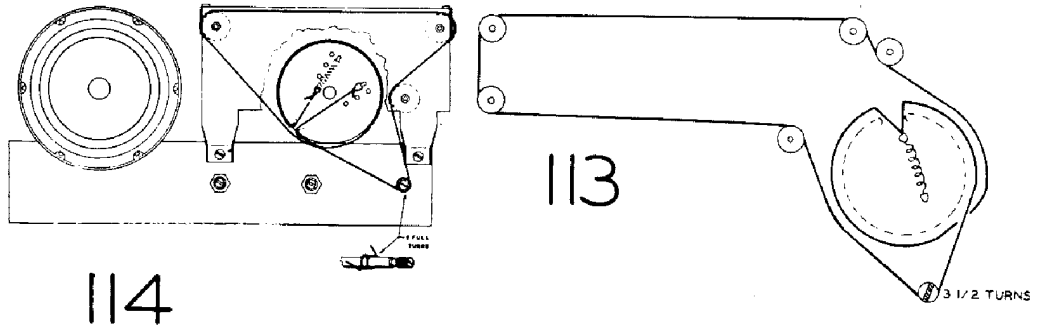

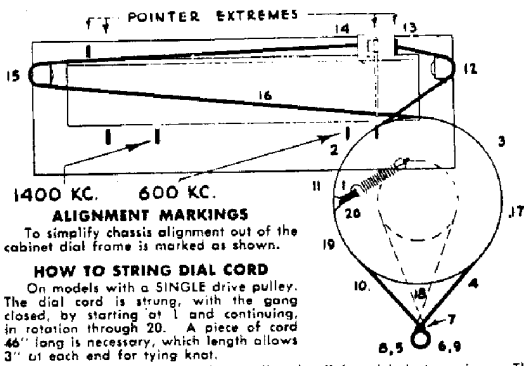

1400 KC. 600 KC.
ALIGNMENT MARKINGS
 To simplify chassis alignment out of the cabinet dial frame is marked as shown.

HOW TO STRING DIAL CORD
 On models with a SINGLE drive pulley. The dial cord is strung, with the gang closed, by starting at 1 and continuing, in rotation through 20. A piece of cord 46" long is necessary, which length allows 3" at each end for tying knot.

On models with DOUBLE drive pulley the dial cord is in two pieces. The pointer cord is on the large pulley starting at 1 and continuing through 20 BUT in the following special order, 1, 2, 3, 4, 18, 19, 11, 12, 13, 14, 15, 6, 17, 18, 19, 20. The drive cord is on the smaller dotted pulley, in the dotted position.

To clarify dial cord arrangement the dial frame is shown as transparent.

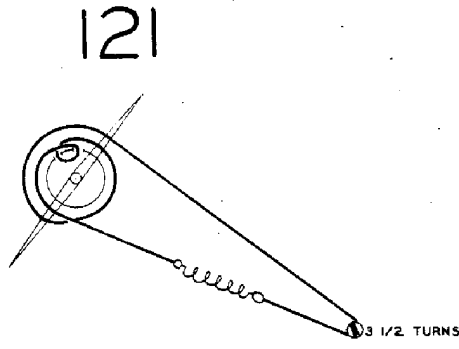

122

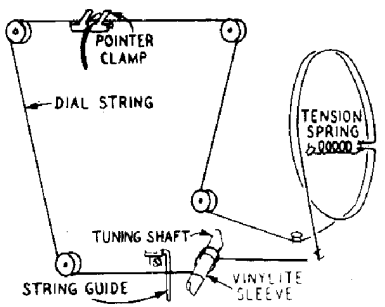

123

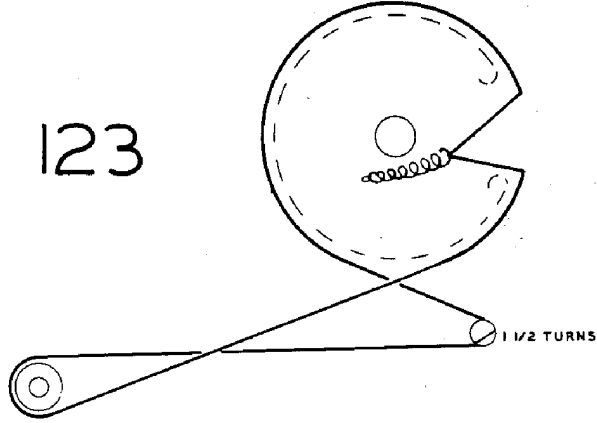

124

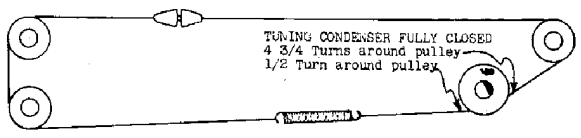

125

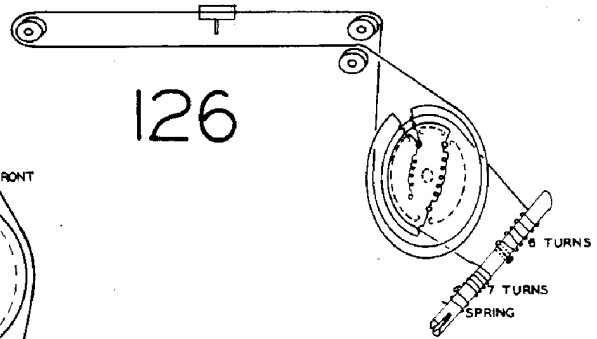

126

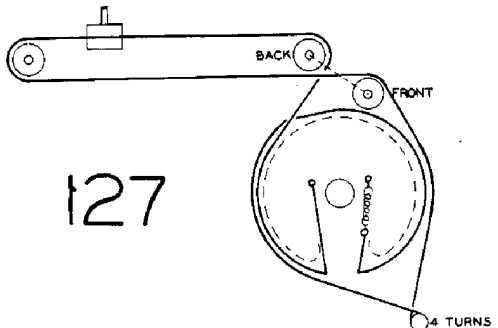

127

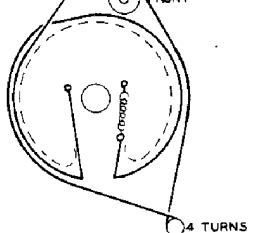

128

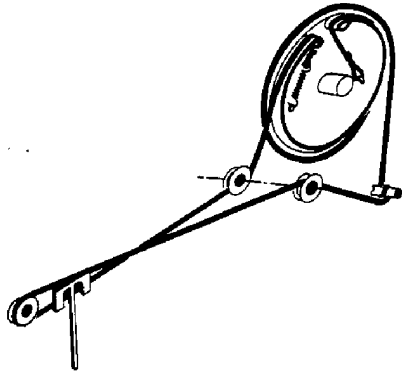

129

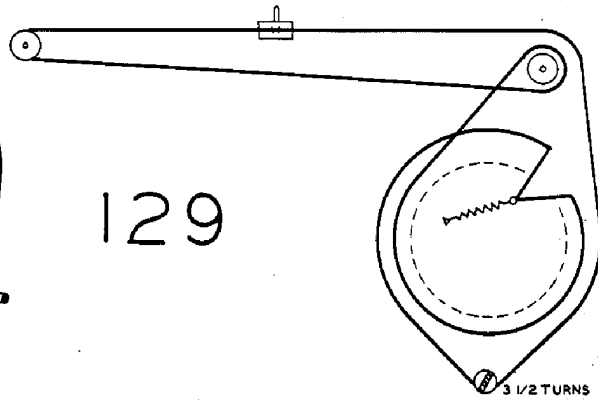

130

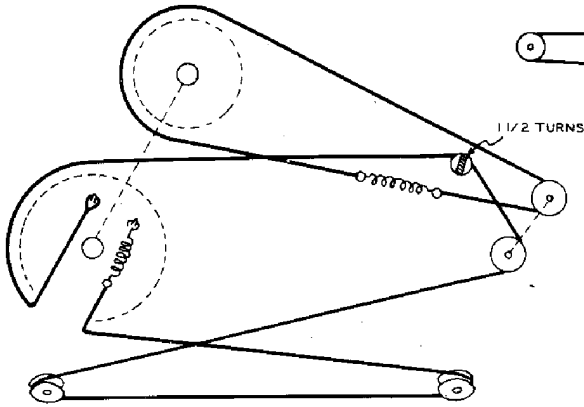

131

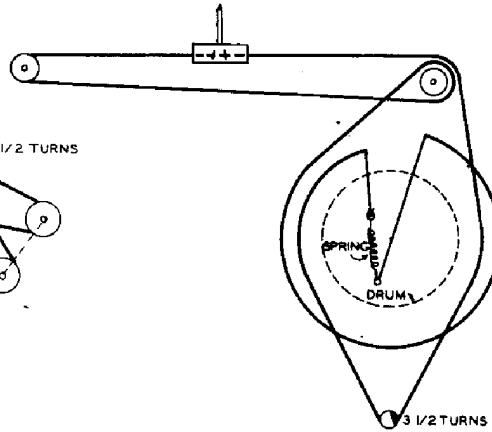

132

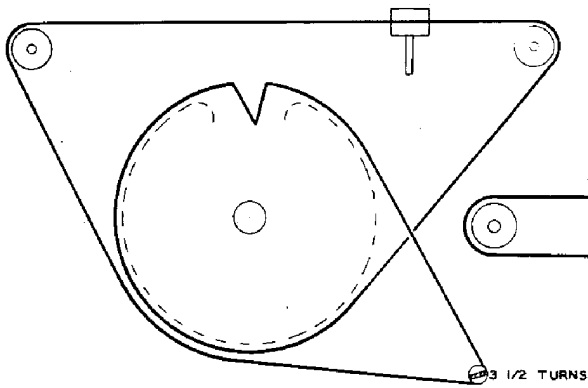

133

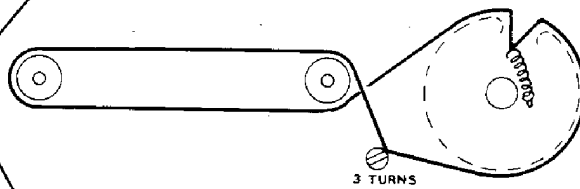

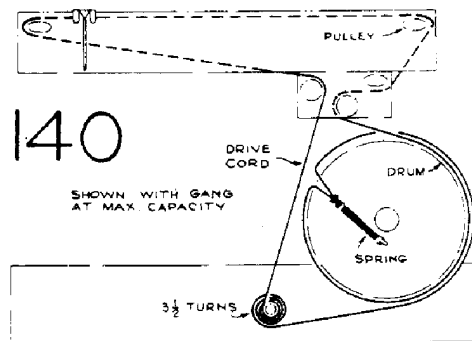
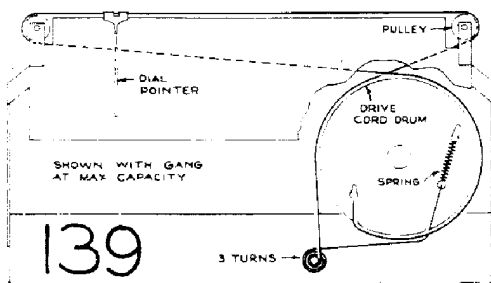
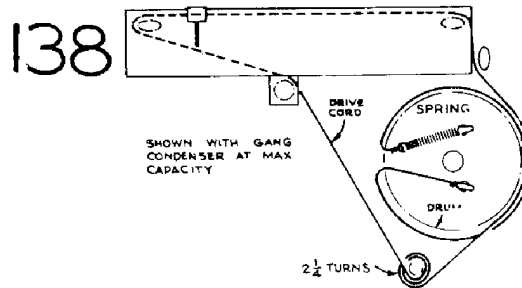
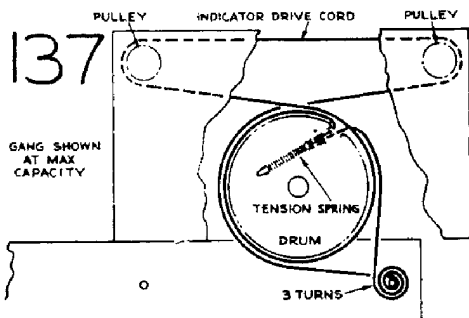
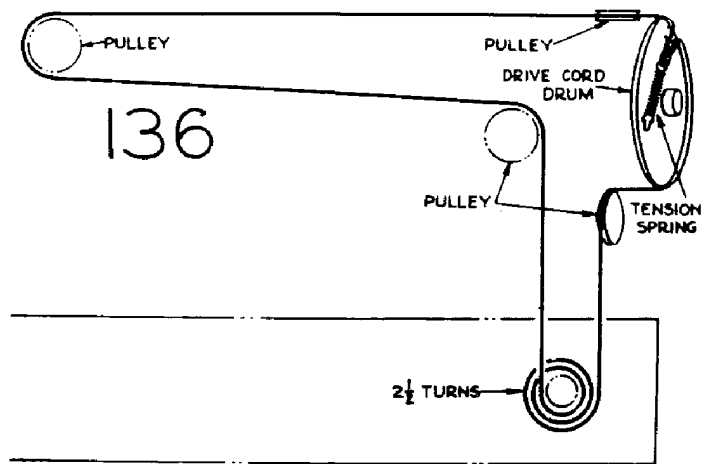
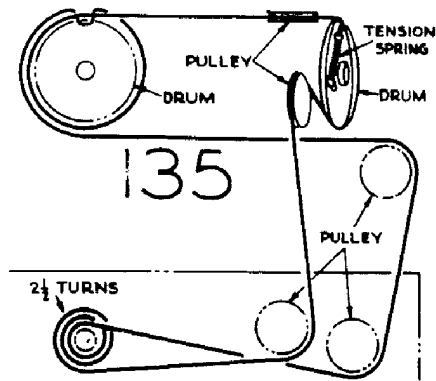
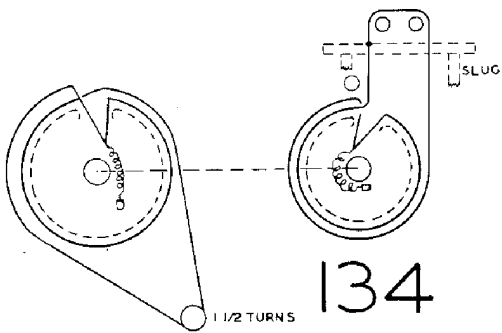

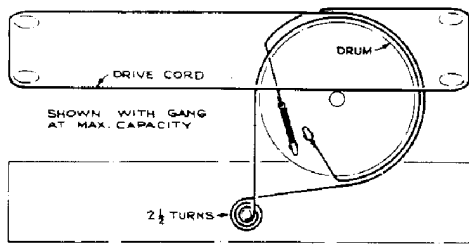

141

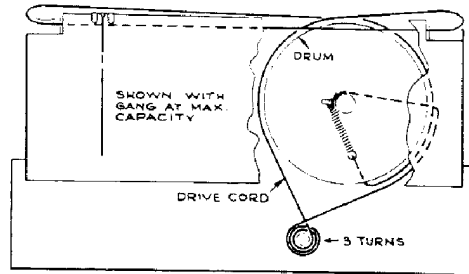

142

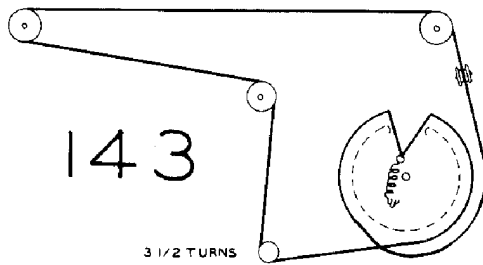

143

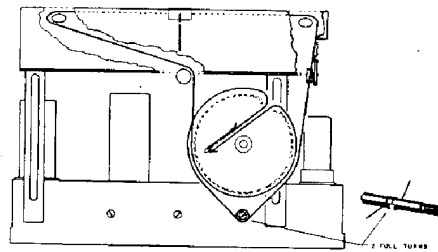

144

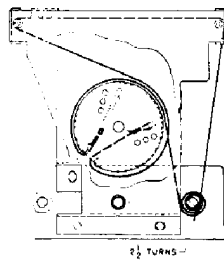

145

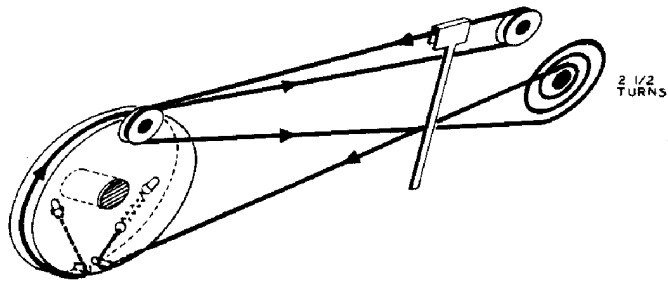

146

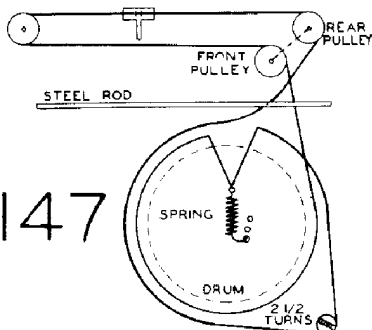

147

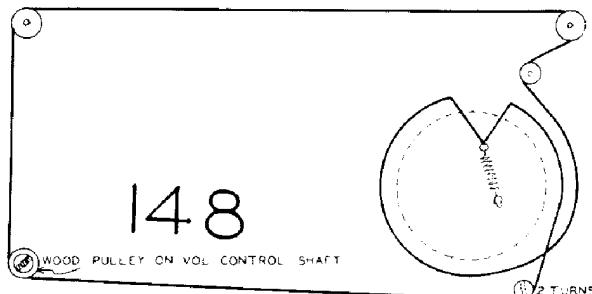

148

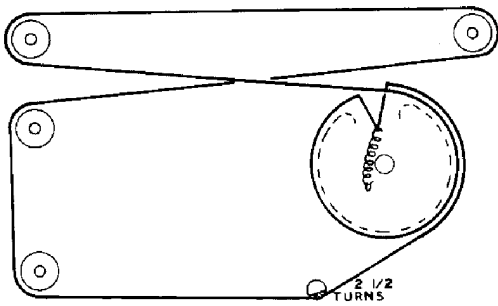

149

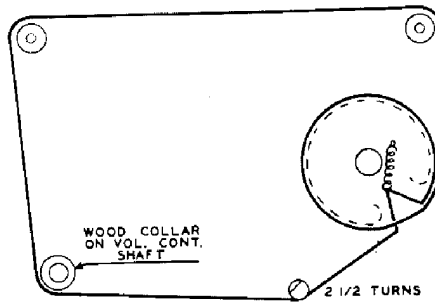

150

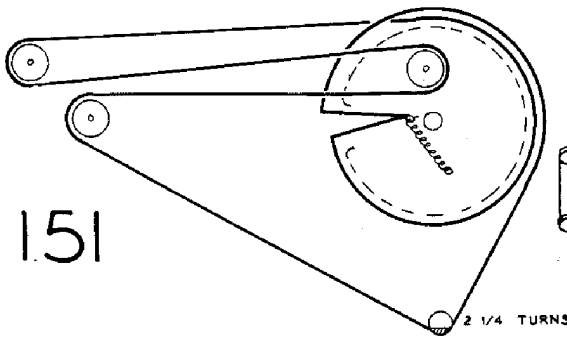

151

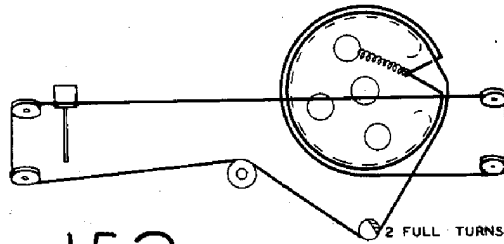

152

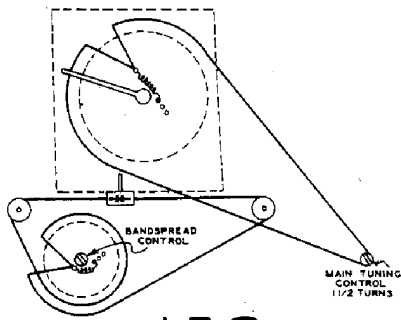

153

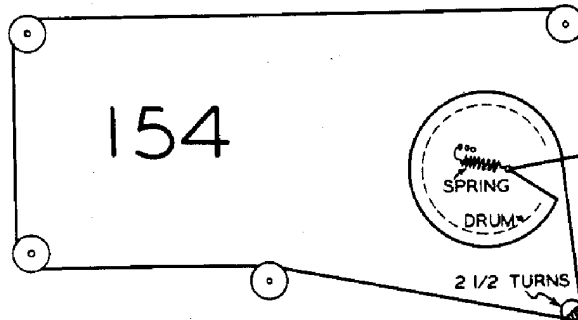

154

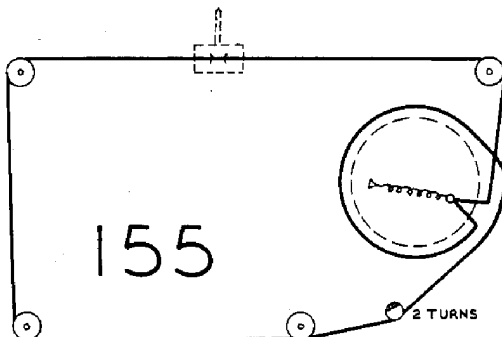

155

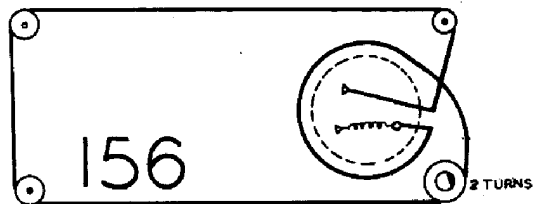

156